



**A**dvanced **G**reen **E**nergy & **C**ontrol

## Alarm Module With Data Logger

**M A N U A L**



**AM Series – Ver.1**  
**April 2018**

---

8Z Block – Belal ben Rabah St. – Alnozha Algageda – Cairo – Egypt – Tel/Fax: 02-26230107  
Website: [www.agec-eg.com](http://www.agec-eg.com) E-mail: [design@agec-eg.com](mailto:design@agec-eg.com)

---

# Index

Content	Page
<b>1. Safety cautions</b>	<b>3</b>
<b>2. Features</b>	<b>3</b>
<b>3. Device identification</b>	<b>4</b>
<b>3.1 Front</b>	<b>4</b>
<b>3.2 Terminal Connection</b>	<b>4</b>
<b>4. Operation theory</b>	<b>5</b>
<b>5. Operation procedures</b>	<b>6</b>
<b>5.1 Start up</b>	<b>6</b>
<b>5.2 Faults</b>	<b>6</b>
<b>5.3 Data logging</b>	<b>8</b>
<b>5.4 Settings</b>	<b>8</b>
<b>5.4.1 Set time</b>	<b>9</b>
<b>5.4.2 Set date</b>	<b>9</b>
<b>5.4.3 Change password</b>	<b>10</b>
<b>5.4.4 Erase old events</b>	<b>10</b>
<b>6. Notes</b>	<b>11</b>
<b>7. Technical Specifications</b>	<b>12</b>
<b>7.1 Electrical Specifications</b>	<b>12</b>
<b>7.2 Mechanical Specifications</b>	<b>12</b>
<b>7.3 Protection Specifications</b>	<b>12</b>
<b>8. Panel Cutout</b>	<b>13</b>
<b>9. Ordering information</b>	<b>13</b>

**For your safety, please read the following before using.**

## **1. Safety Cautions**

### **Warning**

**1. It must be mounted on Panel.**

It may give an electric shock.

**2. Do not connect terminals while power on.**

It may give an electric shock.

**3. Do not disassemble and modify this unit. If it is necessary please contact us.**

It may give an electric shock and cause fire.

**4. Please check the terminals numbers when connecting power lines.**

It may cause fire.

**5. When cleaning the unit, do not use water or an oil-based detergent.**

It may cause an electric shock or fire and so the unit will be damaged.

**6. Please connect properly after checking the polarity.**

It may cause fire.

## **2. Features:**

1- Two universal (AC or DC) power supply.

2- Data logging for the alarm signals.

3- Real time clock.

4- Auxiliary output 24 VDC to supply signals from the device (Option).

5- Response time 25 msec.

6- 8,16,24 or 28 channel observation with optical isolation.

7- 8,16,24 or 28 channel can be common positive or negative.

8- 8,16,24 or 28 red bar Led for fault indication.

9- Four free contact for fault indication.

10- 8,16,24 or 28 output relay work as repeater for each input.

11- Two red 5 mm Led for two sources fault indicator.

12- Two green 5 mm Led for two sources ON.

13- One yellow 5 mm Led for the device ready.

14- Five push buttons for deal with the fault, preview the log and setting.

15- Easy fixation in panel.

16- Easy alarm label insertion.

17- Easy terminal block.

# 3. Device identification

## 3.1. Front

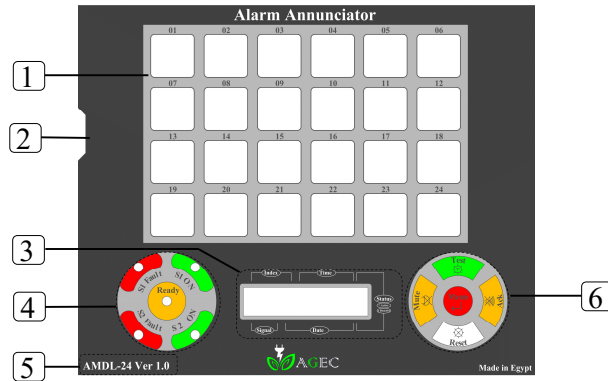

- 1 Alarm led indicator.
- 2 Alarm label paper insertion position.
- 3 Log display (2 \* 16 Character LCD).
- 4 Status led indicator (Source 1 ON – Ready – Source 2 ON).  
Alarm led indicator (Source 1 Fault - Source 2 Fault).
- 5 Model number.
- 6 5 tactile push button keys (Test / Up – Reset / Down – Ack / Right - Mute / Left – Menu / Enter).

## 3.2. Terminal Connection

For Example: AM-XR-21-24-0

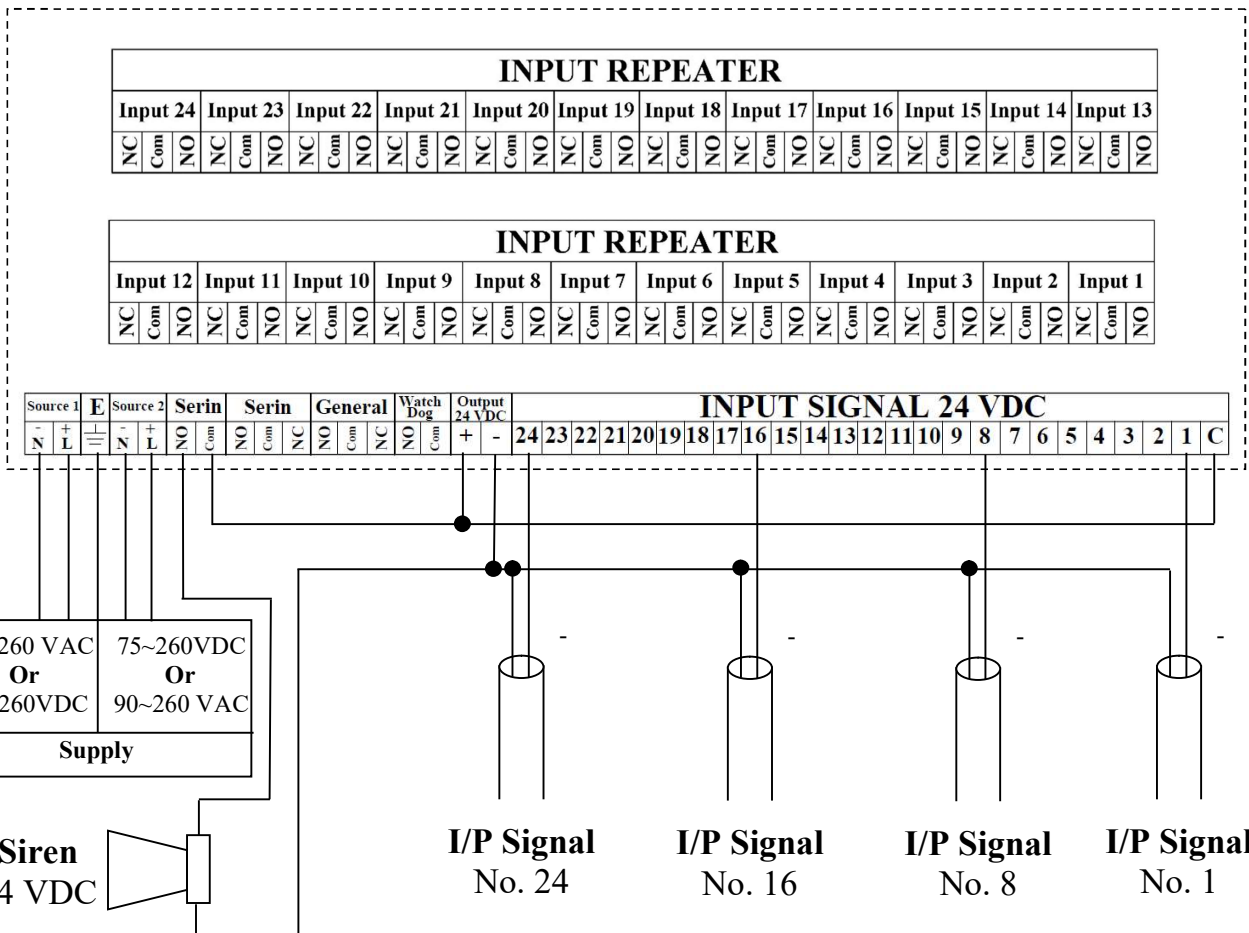

## For Example: AM-XR-20-24-0

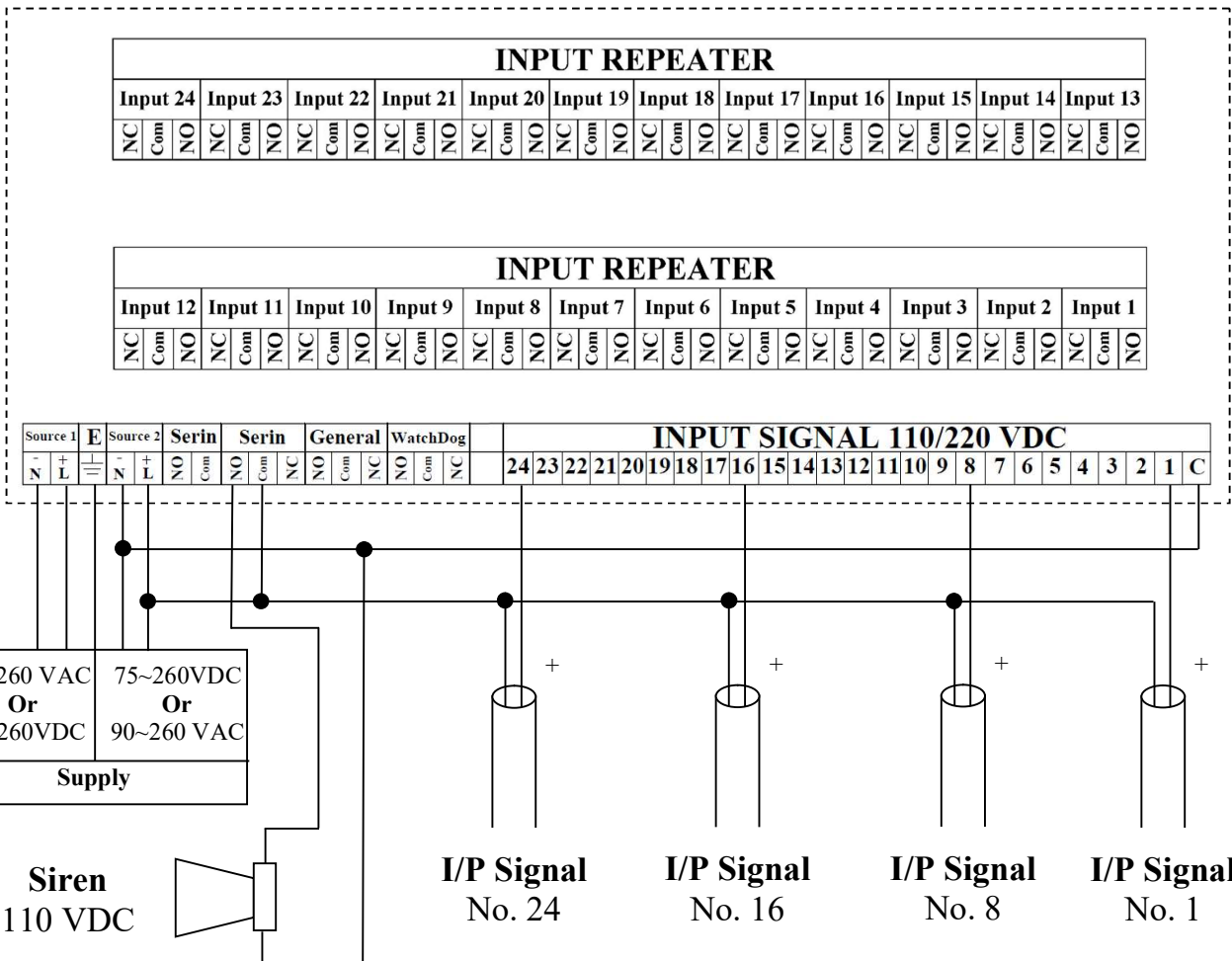

## 4. Operation theory

The AM Series-Ver 1.0 used to observe the Transformers stations where it can monitor the status of all protection devices such as oil level, oil temperature, coil temperature, transformer load, gas pressure of CB and others.

We add new feature in the version (AM-DX-XX-XX-X) where the device can store 8000 fault signals with real time.

The AM Series-Ver 1.0 after connecting to the power, it make self-test for all leds and relays and then :

- The two-green power leds light.
- If there isn't internal error the orang ready led flashing.

- If there is any fault of the two sources the intended led will flash and the free contacts (**General [No-Com]** and **Serin [No-Com]**) will become in close position.
- If there is any fault any input the intended led will flash and the free contacts (**General [No-Com]** and **Serin [No-Com]**) will become in close position.
- Any fault will be stored in the EEPROM of the device with real time and the user can navigate all faults in LCD by using Keypad.

The AM Series -Ver 1.0 contain 5 tactile push button keys used to acknowledge the alarm, Mute the internal buzzer, reset the alarm, test all led and free contacts from relays, navigation in faults recorder and adjust the time, date and password.

## 5. Operations Procedures:

### 5.1. Start up:

First when connect power to the LCD will show the following:



AGEC  
TEL: 02-26230107

Then for example

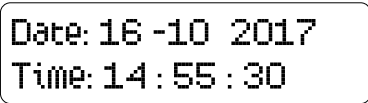

Date: 16 -10 2017  
Time: 14 : 55 : 30

And make self-test for all Leds and relays.

### 5.2. Faults

When fault occur (75 to 250 VDC in 110/220 case or 12 to 36 VDC in 24 case in model AM-XX-X<sub>1</sub>-XX-X) on any inputs the intended led will flash (visual alarm) and the free contacts (**General [NO-Com]** , **Serin [NO-Com]** & **Serin [NO-Com-NC]**) will become in close position and if siren connected to free contact, it will make audio alarm.

And also if there is any fault of the two sources the intended led will flash and the free contacts (**General [NO-Com]** , **Serin [NO-Com]** & **Serin [NO-Com-NC]**) will become in close position.

The **Ack**  push button is used to silence the Serin where after fault occur and when the user press Ack button the intended led will light continuance and the free contacts **Serin [No-Com]** & **Serin [NO-Com-NC]** will become in open position.

The **Mute**  push button is used only to silence the internal buzzer that is involved in the unit.

The **Reset**  push button is used to reset the alarm where after the user press Ack button, the operator will need to know the alarm reason is still or not, so he presses Reset button where if the alarm reason is still, only is led is flashing again but if the alarm reason clear, the intended led will extinguish and the free contacts **General, Serin [No-Com]** & **Serin [NO-Com-NC]** will become in open position.

The **Test**  push button used to test the operation of all led (alarm LEDs and status LEDs) and free contacts.

Note that **Watch Dog [NO- Com]** relay will be close as long the unit is powered and is healthy and the ready led is flashing.

The AMDL Ver 1.0 can supplied with main supply (AC) or backup batteries (DC) where there is 2 green led for power on and 2 red led for the failure for each supply.

The **AMDL - Ver 2.0** also contain power supply out 24 VDC to feed all alarm channels so we can insure that the overall system work well.

### 5.3. Data logging:

The AMDL - Ver 1.0 store the alarm that occurred, and the operator can read the old events in 2\* 16-character LCD by push button.

In the startup of the device, the LCD show the date and clock.

```
Date: 16 10 2017
Time: 14 : 55 : 30
```

When the alarm occurred, the LCD show the alarm index, time, channel number and date and still show the last alarm for 1 minute.

```
<0038> - 09:20:32 *
<23> - 07:11:2017 *
```



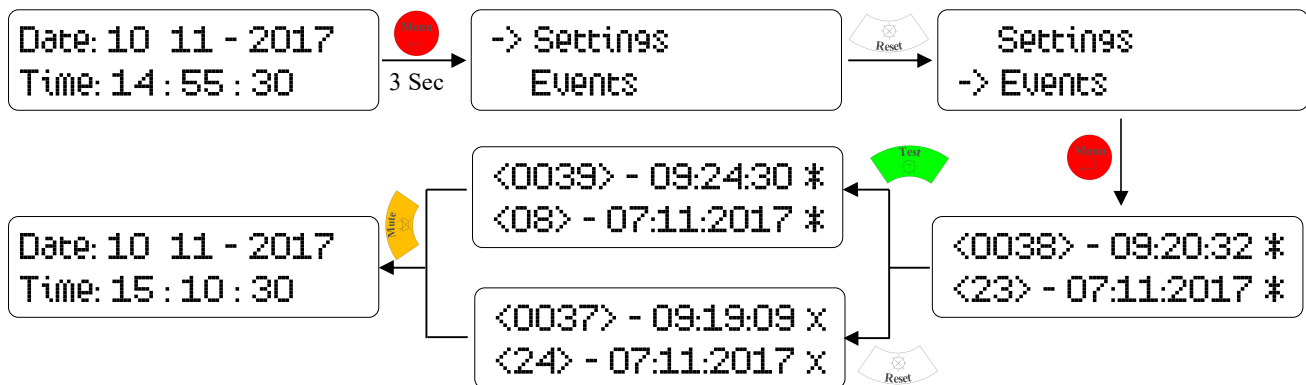

The operator can navigate all old alarms as following:

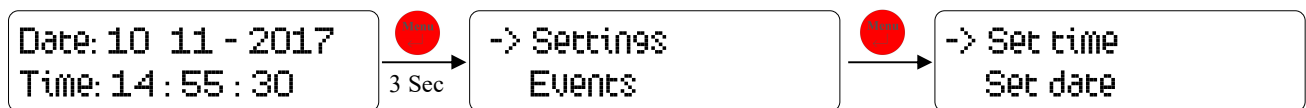

### 5.4. Settings:

The operator can set time, date, change password and erase old events as following:



- Use Menu  push button to enter the selected menu.
- Use Test / Up  push button to scroll up or increase the value.
- Use Reset / Down  push button to scroll down or decrease the value.
- Use Mute / Left  push button to shift left.
- Use Ack / Right  push button to shift right.



### 5.4.1 Set time:

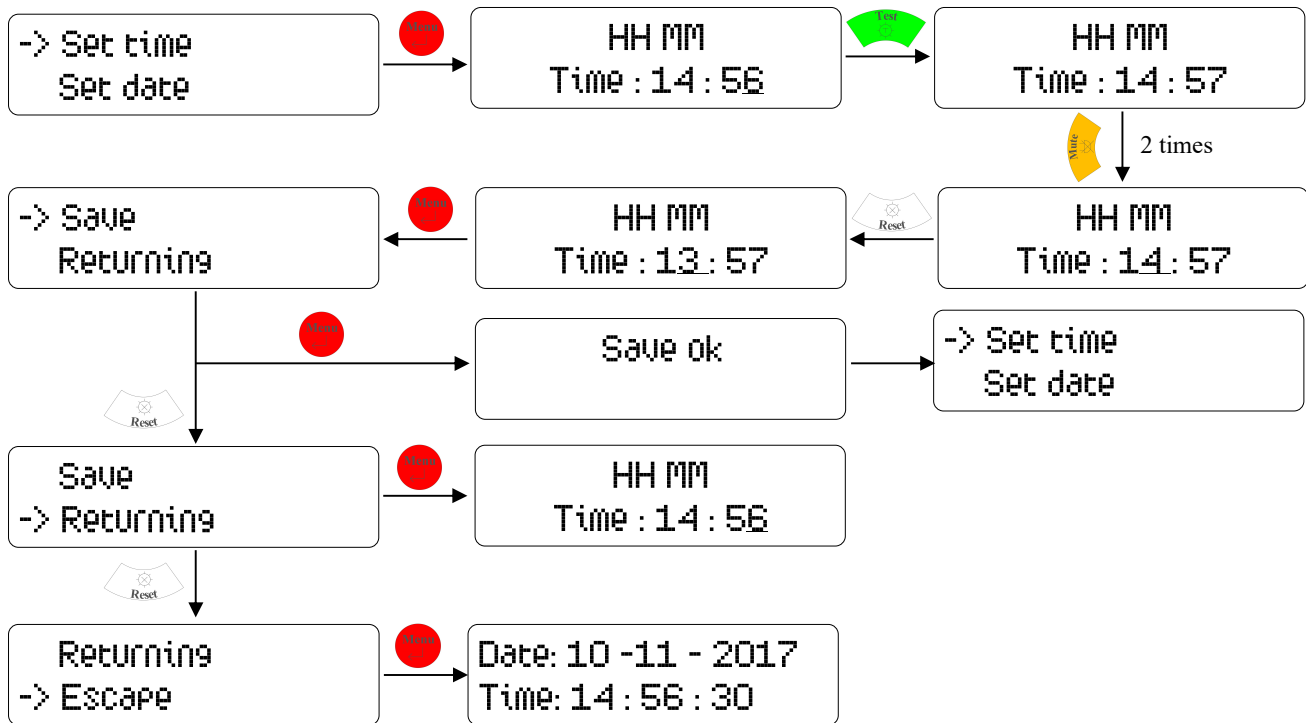

### 5.4.2 Set date:

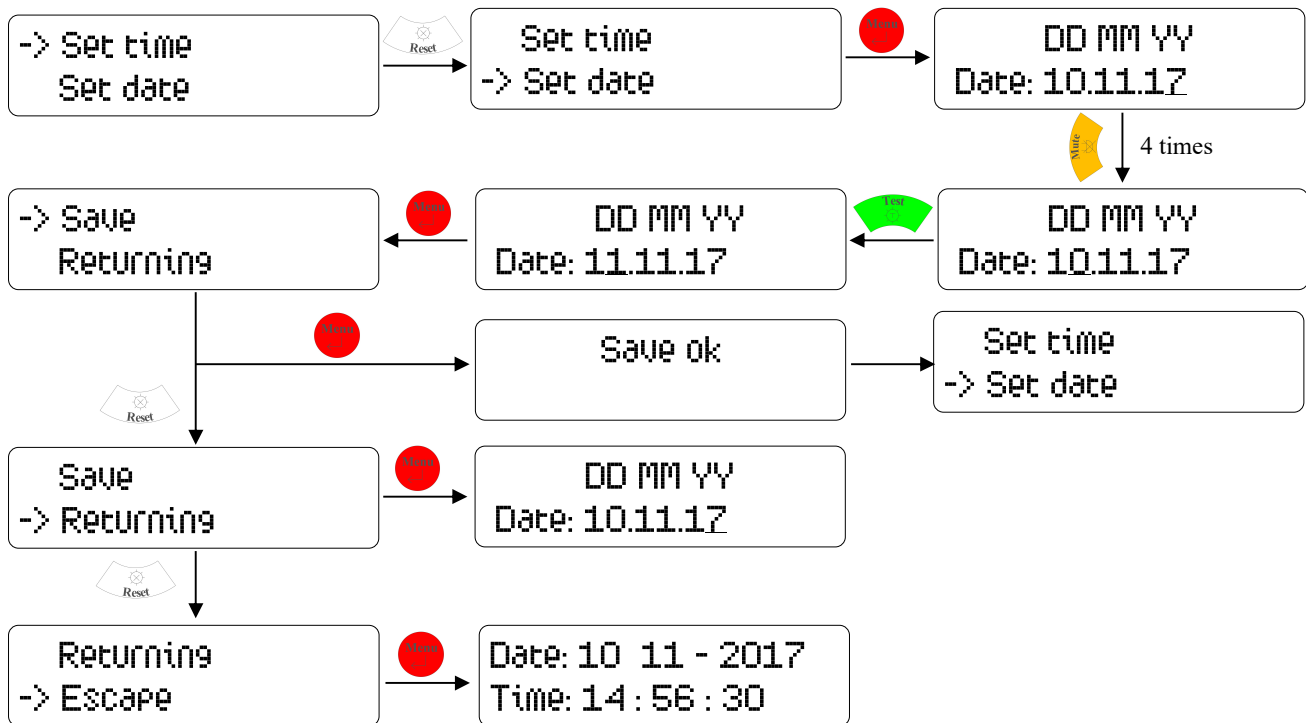

### 5.4.3 Change password

The default password is: 1111

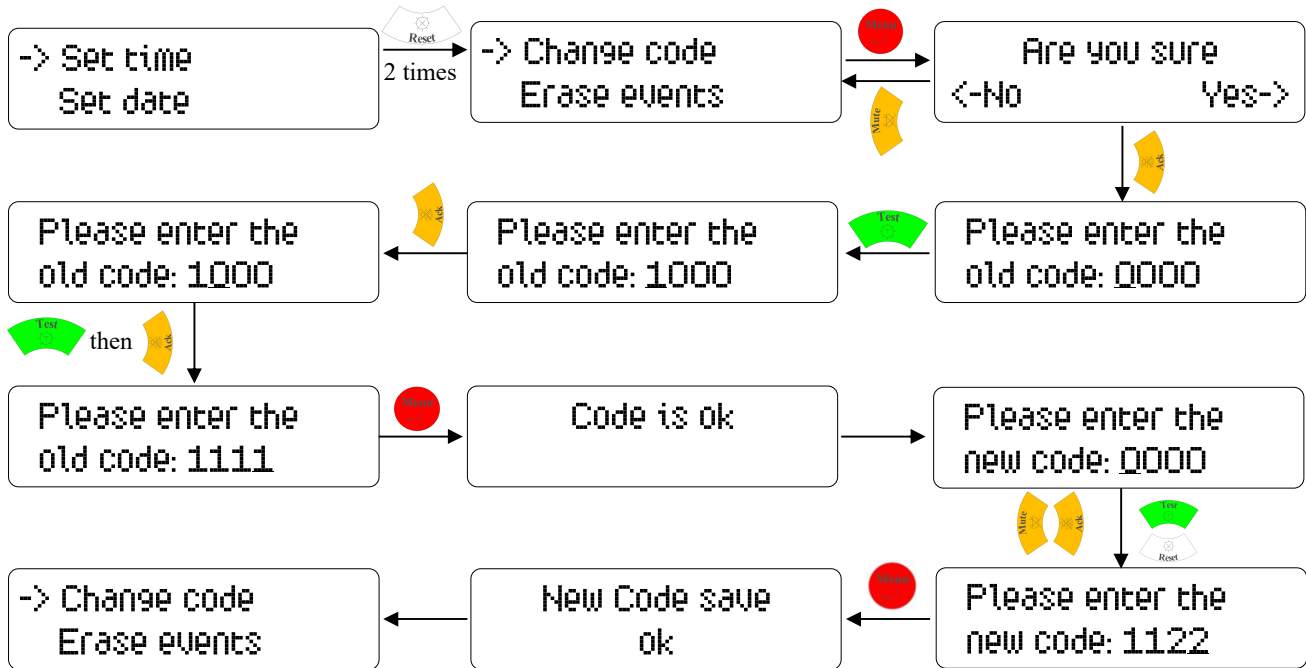

### 5.4.4 Erase old events:

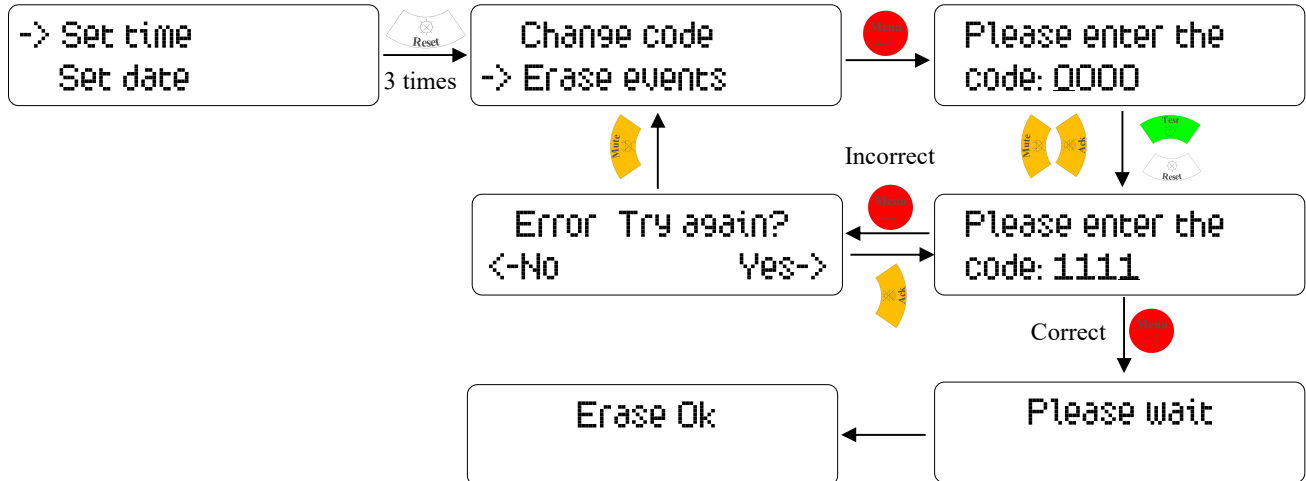

## 6. Notes:

- General fault relay [NO – Com - NC] Form C becomes in close position when the any of two sources fails or any input become active.
- Watch Dog relay [NO – Com - NC] Form C becomes in close position when source 1 fault, source 2 fault or any input become active
- Serin relay [NO – Com] Form A & [NO – Com - NC] Form C become in close position when source 1 fault, source 2 fault or any input become active.
- Watch Dog relay [NO – Com - NC] Form C is changed to normally open position (Form A) from internal jumper in case of 24 VDC output in model AM-XX-X1-XX-X.
  
- **Mute button:** silence the internal buzzer.
- **Ack button:** deactivate the serin relay.
- **Reset button:** deactivate all LEDs and relays when the cause of the fault is removed especially the general relay.
- **Test button:** used to test all LEDs and relays.
- When the Memory of data logger is full, the screen will show:

Full Memory

The ready LED will light continually, and the internal Buzzer will work.

The Device won't store any new data, So the user should erase the old events as in 5.4.4

## 7. Technical Specifications:

### 7.1 Electrical Specifications:

#### Power:

- 75 to 260 VDC (universal power supply).
- 90 to 260 VAC (universal power supply).

#### Inputs:

- 75 to 250 VDC (8 , 16 , 24 or 28 inputs) optically coupled.
- 12 to 36 VDC (8 , 16 , 24 or 28 inputs) optically coupled in model AM-XX-X<sub>1</sub>-XX-X.

#### Outputs:

- 8, 16 , 24 or 28 LEDs.
- 4 relay free contact (10 A for one) can selected NO or NC.
- 8, 16 , 24 or 28 form C relay (NC-NO) free contact (4 A for one) as each input repeater.
- 24 VDC aux. power supply – 1A (Option).

### 7.2 Mechanical Specifications:

**Dimension** : 25.0 cm \* 20.3 cm \* 6.0 cm

### 7.3 Protection Specifications

**Temperature** : 0°C to +50°C

**Enclosure IP** : IP 45

- The enclosure is isolated according to standard EN 60439-1 specification.
- The enclosure is protected against external mechanical shocks

## 8. Panel Cutout

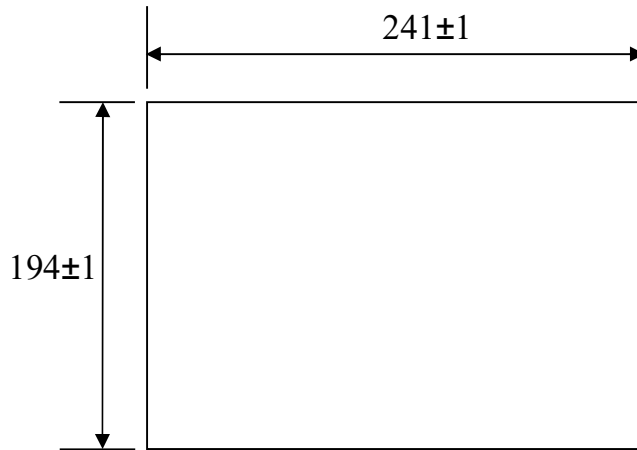

(Unit: mm)



Fixation clips in panel

## 9. Ordering information

AM – X X – X X – X X – X						
AM						Alarm Module Sires.
Data Logger	0 D					No data logger. Data logger.
Input repeater		0 R				No repeater for input. Repeater for each input.
Power supply			1 2			One universal power supply. Two universal power supply.
Aux. supply				0 1		No aux. output 24 VDC. Aux output 24VDC.
No. of channels					08 16 24 28	8 channel inputs. 16 channel inputs. 24 channel inputs. 28 channel inputs.
Communication					0 1 2	No communication RS232 USB

## Notes

.....

.....

.....

.....

.....

.....

.....

.....

.....

.....

.....

.....

.....

.....

.....

.....

.....

.....

.....

.....

.....

.....

.....

.....

.....

.....

.....

.....

.....

.....

.....

.....

.....

.....

.....

.....

.....

.....

.....

.....

.....

.....

.....

.....





🏠 Head office :

8Z block, Belal ben Rabah St. , New Nozha, Cairo, Egypt

☎ +202 26230107

☎ +202 26200780

🏭 Factory:

Industrial Zone B&C, El Obour City Cairo, Egypt

☎ +202 44873051